

sarbak



TECHNICAL DATA SHEET

CW509L - CuZn40

S509 - S509DW
RODS / HOLLOW RODS

Product Code	EN Symbol	EN No	ASTM		Cu	Zn	Pb	Sn	Fe	Ni	Al	Si	Others Total
S509	CuZn40	CW509L	C27450	Min (%)	59,0	Rem.	-	-	-	-	-	-	-
				Max (%)	61,5	Rem.	0,2	0,2	0,2	0,3	0,05	-	0,2
(*) S509DW	CuZn40-DW	CW509L-DW	C27450	Min (%)	59,5	Rem.	-	-	-	-	-	-	-
				Max (%)	61,5	Rem.	0,2	0,2	0,2	0,2	0,05	0,02	0,2

(*) Each of the other elements < 0,02 %

Features And Applications

Chips and parts can be mixed with MS58 group alloys. Also this alloy compliance with RoHS II and REACH directives. CW509L-DW alloy be used suitable for 4MS vs UBA list for drinking water applications.

4MS and UBA Hygienic list group for CW509L-DW alloy: B, C, D

Area of Usage

Construction, automotive, gas, food, health, aviation, electrical, electronics, plumbing, drinking water products, accessories and fittings. Also this alloy suitable for drinking water application in USA and Canada Markets because of the lead content below 0.2%.

TECHNICAL SPECIFICATIONS

Structure	$\alpha+\beta$	Hot Forming	650-750 °C
Machinability	% 50	Soft Annealing	450-550 °C
Density	8,4 g/cm ³	Soft Annealing Time	1-3 hours
Electrical Conductivity	25 %IACS	Stress Relieving	200-250 °C
Thermal Conductivity	122 W/(m·K)	Stress Relieving Time	1-3 hours
Elasticity Module	105 GPa		
Coeff. of Thermal Expansion	20,8 10 ⁻⁶ /K		
Melting Point	880-910 °C		

Range of Products

S509L and S509L-DW alloys can be produced in our extrusion and cold drawing unit as rods, hollows and profiles suitable for both forging and machining. Please contact us for other technical informations.

INDICATIVE SHAPED ENDS DIMENSIONS

Nominal Diameter or Width		Type A - Chamfer Length(L)		Type B - Point Length(L)	
Across-flats (mm)		Min (mm)	Max (mm)	Min (mm)	Max (mm)
Over	Up to and including				
-	10	0,2	1,5	2	7
10	20	0,2	2	3	10
20	30	0,2	3	4	12

Unless otherwise specified by the buyer, the shape of the ends of products larger than 30 mm is up to the supplier.

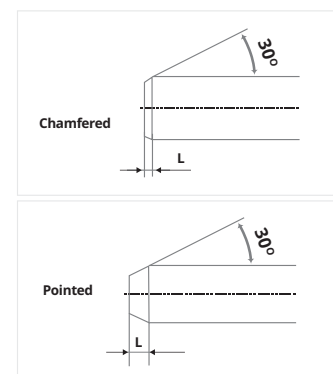

Nominal Diameter or Width Across-flats (mm)		Preferred (available) Lengths (mm)	Tolerance on Length (mm)
Over	Up to and including		
10 Inc.	30	3.000 - 4.000	±50
30	65	3.000 - 4.000	±100

Stress Relieving The polygonal rods and hollow rods are subjected to stress relieving treatment

Packaging 500 or 1000 kg bundle – 3/5 metal straps different bundle packagings, up to 10 mm dimension products are packed with wooden case

EN 12164 - Rods for Free Machining

Material Condition	Nominal Diameter (mm)		Width Across-flats (mm)		Tensile Strength R _m N/mm ² (MPa) Min	0,2 % Proof Strength N/mm ² (MPa)		Elongation			Hardness (HBW)	
	Over	Up to and inc.	Over	Up to and inc.		Min	Max	A _{100mm} (%)	A _{11,3} (%)	A (%)	Min	Max
M	All		All		As manufactured							
R360	10	65	10	55	360	-	300	-	15	20	-	-
H070	10	65	10	55	-	-	-	-	-	-	70	100
R410	10	40	10	35	410	230	-	8	10	12	-	-
H100	10	40	10	35	-	-	-	-	-	-	100	145
R500	10	14	10	10	500	350	-	3	5	8	-	-
H120	10	14	10	10	-	-	-	-	-	-	120	-

EN 12168 - Hollow Rods for Free Machining

Material Condition	Wall Thickness (mm)		Tensile Strength R _m N/mm ² (MPa) Min	0,2 % Proof Strength N/mm ² (MPa)		Elongation A (%) Min	Hardness (HBW)		Hardness (HV)	
	Over	Up to and inc.		Min	Max		Min	Max	Min	Max
M	All		As manufactured							
R360	4	20	360	-	300	20	-	-	-	-
H070	4	20	-	-	-	-	70	100	80	110
R410	4	10	410	250	-	12	-	-	-	-
H100	4	10	-	-	-	-	100	145	110	155
R500	4	7	500	350	-	8	-	-	-	-
H120	4	7	-	-	-	-	120	-	130	-

EN 12165 - Wrought and Unwrought Forging Stocks

Material Condition	Nominal Diameter (mm)		Hardness (HBW)	
	Over	Up to and including	Min	Max
M	All		As manufactured	
H070	10	65	70	100

STANDARD		EN 12164			EN 12165		EN 12168					
Dimension Range		Round Rod		Hexagonal, Square	Round Rod		Round and Hexagonal Hollow Rod, Outer Dim. Tol.			Hole Tolerance Round		Hole Tol. Hexagonal
Over	Up to & inc.	Class A	Class B	Rod	Class A	Class B	Class A	Class B	Class C	Class A	Class B	-
-	10	0 -0,06	0 -0,036	0 -0,09	±0,25	±0,14	-	-	-	-	-	-
10	13	0 -0,07	0 -0,043	0 -0,11	±0,25	±0,14	-	-	-	-	-	-
13	18	0 -0,07	0 -0,043	0 -0,11	±0,25	±0,14	-	-	-	±0,35	-	+0,70 -0
18	20	0 -0,08	0 -0,052	0 -0,13	±0,30	±0,17	-	-	-	±0,42	-	+0,84 -0
20	23	0 -0,08	0 -0,052	0 -0,13	±0,30	±0,17	-	-	-	±0,42	±0,17	+0,84 -0
23	26	0 -0,08	0 -0,052	0 -0,13	±0,30	±0,17	-	0 -0,21	-	±0,42	±0,17	+0,84 -0
26	30	0 -0,08	0 -0,052	0 -0,13	±0,30	±0,17	-	0 -0,21	0 -0,13	±0,42	±0,17	+0,84 -0
30	50	0 -0,16	-	0 -0,16	±0,60	±0,20	-	0 -0,25	0 -0,16	±0,80	±0,20	+1,6 -0
50	55	0 -0,19	-	0 -0,019	±0,70	±0,37	-	0 -0,46	0 -0,30	±0,95	±0,37	-
55	65	0 -0,19	-	-	±0,70	±0,37	±0,60	0 -0,46	0 -0,30	±0,95	-	-
65	80	-	-	-	±0,70	-	±0,60	0 -0,46	0 -0,30	±0,95	-	-
80	110	-	-	-	±2	-	-	-	-	-	-	-

For Hollow Rods

Minimum wall thickness is 3-4 mm. Eccentricity : % 8 (max.)

" For hollows, maximum outer diameter is 78 mm and maximum producible weight 28 kg in 1 meter."

Outer Cold Drawn - Internal Extruded
Outer Class B - Hole Class A tolerance

Inner-Outer Cold Drawn
Outer Class C - Hole Class B tolerance

Inner-Outer Extruded
Outer Class A - Hole Class A tolerance





Headquarter

Eđitim Mah. Adım Sok. Orjin İş Merkezi No: 10 -18 Kat: 3 Daire No: 39 - 49 34722
Hasanpaşa / Kadıköy / İstanbul / Turkey
T: +90 216 414 45 35 pbx | F: +90 216 414 45 40

Factory

Çerkezköy Organize Sanayi Bölgesi Gazi Osman Paşa Mah. 8.Cad. No: 3 59500
Çerkezköy / Tekirdađ / Turkey
T: +90 282 725 19 60 pbx | F: +90 282 725 19 70